

Features

Sight flow Indicator is the simplest instrument for viewing flow of different type of fluids in the process line.

General Instruments Consortium offers sight flow indicators of following types:

- **Double Window - Plain**
- **Double Window - Rotary Wheel**
- **Double Window - Flapper**
- **Double Window - Drip Tube**
- **Double Window - Ball**
- **Full View**

Double Window - Plain

This type of sight flow indicator is recommended where flow is turbulent. This flow indicator is used to monitor vertical or horizontal flow.

Double Window - Rotary Wheel

This type of sight flow indicator is best suited for the lines carrying dark solutions where rotary movement can be easily detected.



Double Window - Flapper

This type of sight flow indicator is recommended for vertical upward as well as horizontal flow. This flow indicator is suitable for colourless and transparent fluids.

Double Window - Drip Tube

This type of sight flow indicator is particularly recommended for vertically downwards flow lines having intermittent flow e.g. flow lines in distillation columns.

Double Window - Ball

This type of sight flow indicator is suitable for colourless gas flow. Usually recommended for vertically upwards and horizontal flow.

Full View

This type of sight flow indicator is used for viewing the process flow to assure that the flow is continuous or to note the process turbidity, colour etc.

Technical Specifications: Table-1 Material of Construction

Type	Double Window - Plain / Rotary Wheel / Flapper / Drip Tube / Ball, Full View
Body	CS, SS 304, SS 304L, SS 316, SS 316L, others on request
Retainer Flange	CS, SS 304, SS 304L, SS 316, SS 316L, others on request
Cushion / Gasket	C.A.F. / P.T.F.E. / Graphoil
Glass	Toughened Borosilicate
Process Connection	Flanged / Screwed
Fasteners	SS, ASTM A193 Gr. B7 / A 194 Gr. 2H

Face to face distance for all designs

1/2" process connection	FFD = 160mm
3/4" process connection	FFD = 160mm
1" process connection	FFD = 160mm
1 1/2" process connection	FFD = 190mm
2" process connection	FFD = 225mm
3" process connection	FFD = 275mm
4" process connection	FFD = 360mm
6" process connection	FFD = 450mm
8" process connection	FFD = 630mm
10" process connection	FFD = 750mm

- | | |
|------------------|-----------------|
| 1 Body | 7 Cushion |
| 2 Process Flange | 8 Glass |
| 3 Glass Holder | 9 Flapper |
| 4 Cover Plate | 10 Drip Tube |
| 5 Fastener | 11 Rotary Wheel |
| 6 Gasket | |

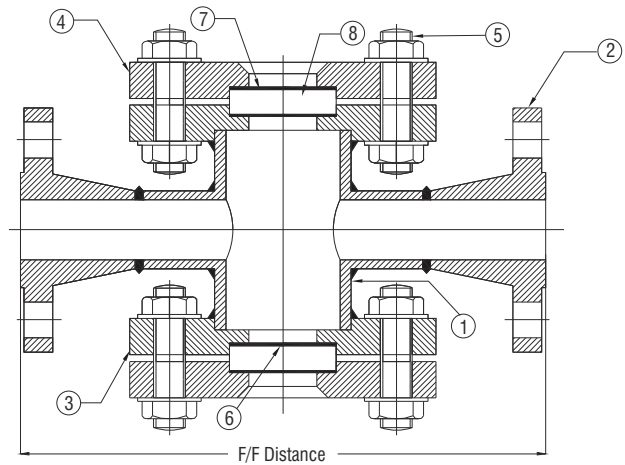

Double Window - Plain

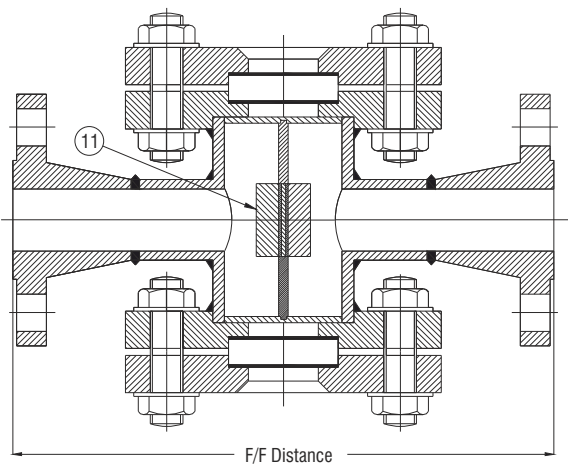

Double Window - Rotary Wheel

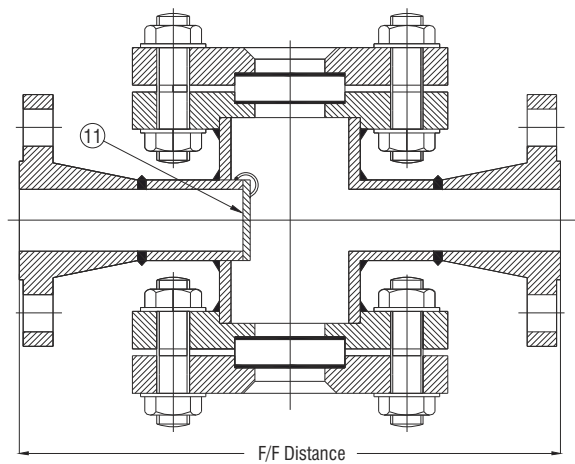

Double Window - Flapper

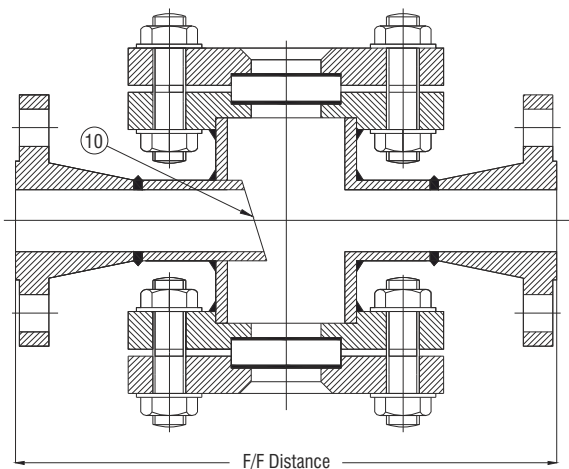

Double Window - Drip Tube

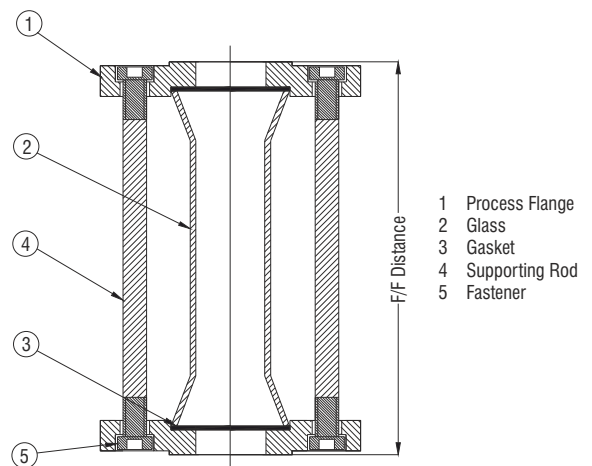

Full View

G A Drawing for assembly and mounting

SFI DWP-F01-WA-VA-VV-WW-XW

